

Model Number
RMCS-3091

**RHINO 24V 30RPM 100W IG55 HEAVY DUTY PLANETARY
GEARED DC MOTOR 150KGCM**

Mechanical Drawing (Dimensions are in mm)

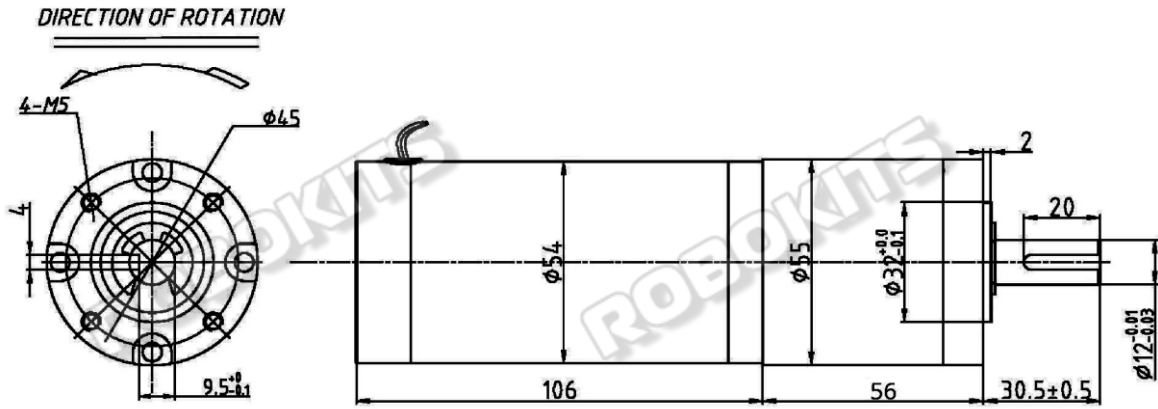

Motor Specifications

Base Motor Diameter	54 mm
Motor Length Without Shaft	163 mm
Base Motor Speed	7000 RPM
No Load Current	0.98 A
Stall Current	Upto 20 A (Max)
Motor Weight	1620 Grams

Gearbox Specifications

Hardened Shaft Diameter	12 mm
Shaft Length	30.5 mm
Mounting PCD	45 mm, 4 Nos - M5 Tapped
Gear Box Diameter	55 mm
Gear Ratio	1:264
Efficiency	0.61%
Number Of Gear Stages	3
Rated Torque	150 kgcm
Stall Torque	280 kgcm
Gearbox Breaking Torque	200 kgcm
Rated Speed	30 RPM
Weight	1.680 Grams



RHINO