

Model Number
RMCS-2095

**RHINO 24V 320RPM 40KG-CM 150W PMDC WORM
GEARED MOTOR**

Mechanical Drawing (Dimensions are in mm)

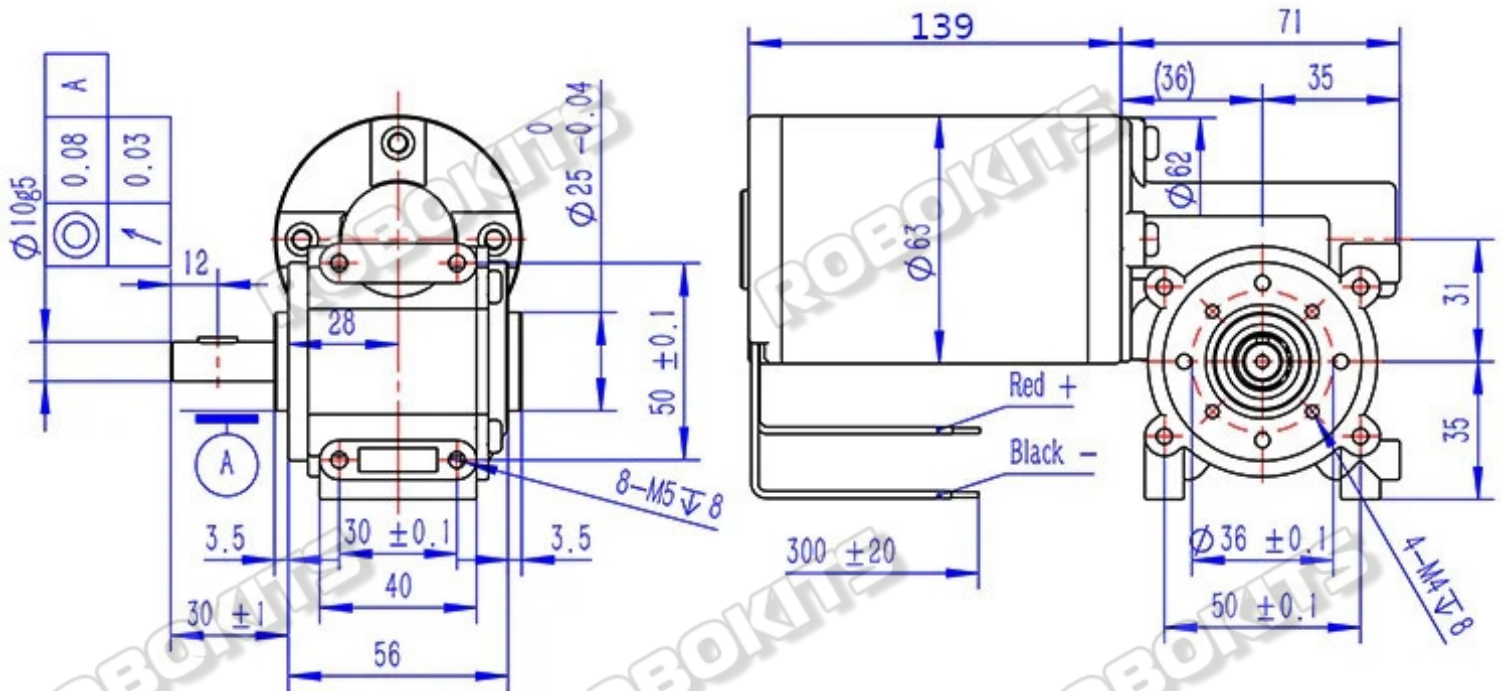

Motor Specifications

Bearing	High Quality Ball Bearing
Magnet	Hard Ferrite, 2-Pole
Protection Class	IP50
Insulation Class	F
Working Temp	-40 C To + 140 C

Worm Gearbox Specifications

Reduction Ratio	10
Efficiency	80%
Weight	0.4 Kg
Axial / Radial Load	300N / 350N

Motor Technical Specifications

Model	150W 320RPM
Rated Voltage	24V DC
Rated Speed	3000 RPM
Rated Torque	0.50 N.m
Rated Current	9.0A
Output Power	150W
No Load Speed	3600 RPM
Weight	1.5 Kg
Motor Length	140 mm

Worm Gear Motor (Motor + Gearbox)

Reduction Ratio	10
Transmission Efficiency	80%
No Load Speed	360 RPM
Rated Speed	320 RPM
Rated Torque	4.0 N.m



RHINO